

Technisches Datenblatt / technical datasheet

EasyLan® 30° Keystone Panel 19" 1HE

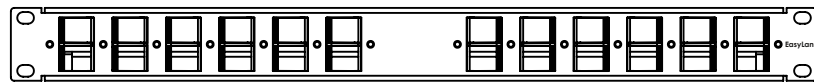

Ausschnittsmaße /
Gap size

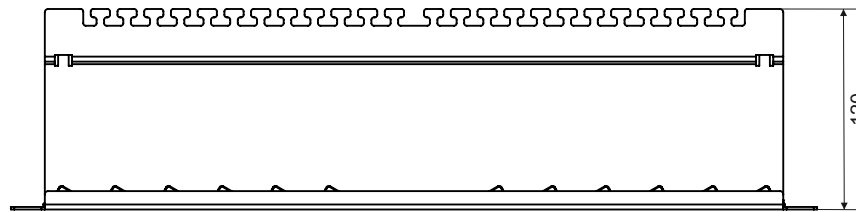
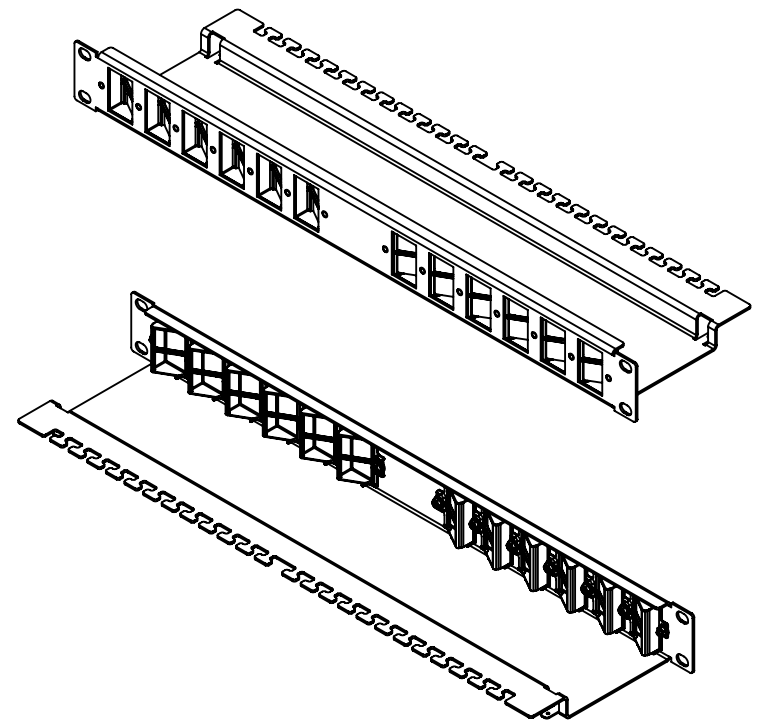
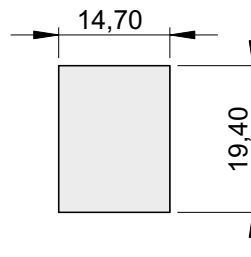

Material	Stahl verzinkt / steel zinc plated	material
Oberfläche	pulverbeschichtet / powder-coated	surface
Adaptermaterial	Zinkdruckguss / zinc diecast	adapter material

c	Änderung Bestell-entf.	02.03.2017	GF	gez. / drawn	13.01.2016	MJ
b	Änderung Itr	13.01.2016	MJ	gepr. / appr.	14.01.2016	GF
a	Neuerstellung	09.09.2015	MJ	Titel / titel: EasyLan® 30° Keystone Panel 19" 1HE für 24 Keystonemodule		
Änd./rev. Index	Änderung/revision code	Datum/date	Name/name	Zeichnungsnummer/ drawing number: ZN-BL151068		



Maße / Dimensions: mm

Original: DIN A4

Blatt / sheet 1 von / of 2

Technisches Datenblatt / technical datasheet

Variante 2 (links/left):

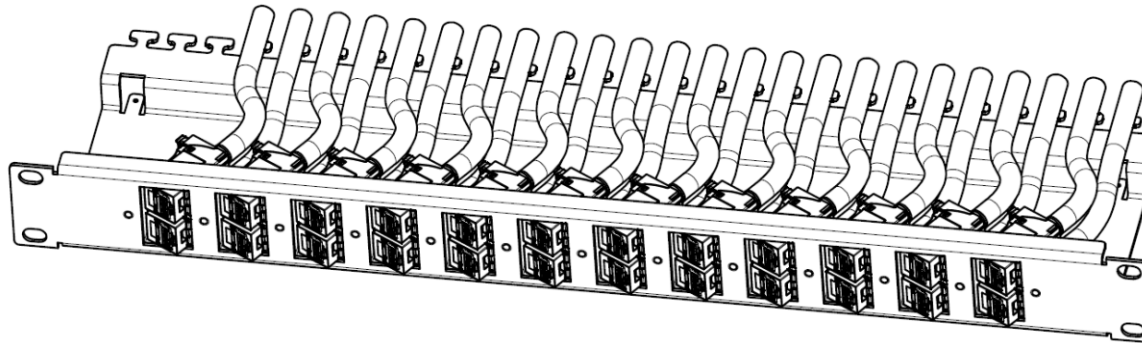

Variante 3 (rechts/right):

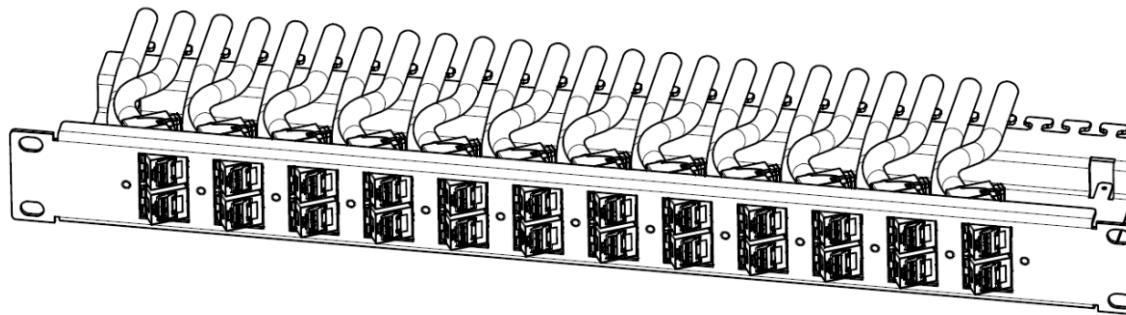

Material	Stahl verzinkt / steel zinc plated	material
Oberfläche	pulverbeschichtet / powder-coated	surface
Adaptermaterial	Zinkdruckguss / zinc diecast	adapter material

c	Änderung Bestell-entf.	02.03.2017	GF
b	Änderung Itr	13.01.2016	MJ
a	Neuerstellung	09.09.2015	MJ
Änd./rev. Index	Änderung/revision code	Datum/date	Name/name
gez. / drawn		13.01.2016	MJ
gepr. / appr.		14.01.2016	GF
Titel / titel: EasyLan® 30° Keystone Panel 19" 1HE für 24 Keystonemodule			
Zeichnungsnummer/ drawing number: ZN-BL151068			



Maße / Dimensions: mm
Original: DIN A4
Blatt / sheet 2 von / of 2