

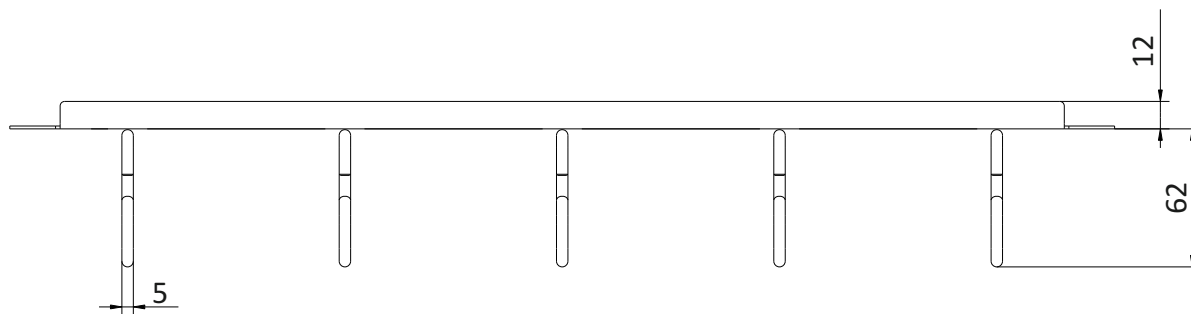

Technisches Datenblatt / technical Data sheet

Rangierpanel 19" 1HE
5x Metallbügel 60mm

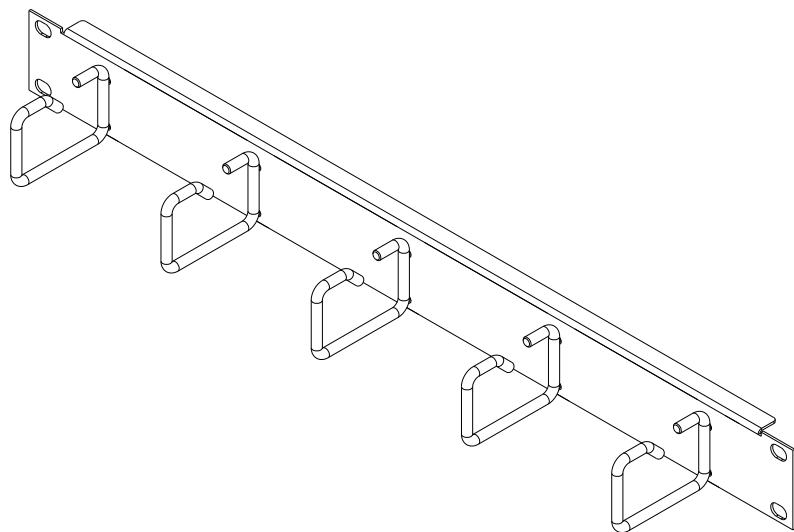
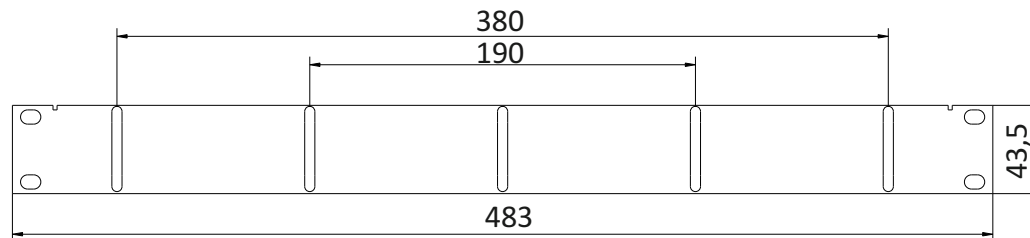

Stahlblech verzinkt, pulverbeschichtet
RAL 7035

Bestell-Nummer
AVR5METC2E

B A	Anpassung Neuerstellung	15.05.18 22.09.15	LP AK	gez. / drawn	22.09.2015	Kandler		
				gepr. / appr.	22.09.2015	Jungbeck		
Titel / title:				EasyLan Rangierpanel 19" 1HE 5x Metallbügel 60 mm				Maße / Dimensions: mm
Änd./ rev. Index				Änderung/ revision code	Datum/ date	Name/ name		Original: DIN A4
				Artikelnummer / article number: ZN-BL151073			Blatt / sheet 1 von / of 1	